

Displaytech® WVGA FLCOS Microdisplay Panel



WVGA Microdisplay Panel Features

- 852 x 480 full-color pixels
- Fast switching ferroelectric liquid crystal (FLC) material eliminates motion smearing
- Full consumer-product temperature ranges with integrated temperature compensation
- Low power: 85mW typical operation
- 60Hz frame rate (360Hz RGB field rate)
- Adjustable gamma settings
- All-digital pixel architecture with superior image quality
- Fully integrated display controller requires no additional circuitry to interface to digital video
- Flexible video interface easily adapts to most digital video sources
- Programmable video cropping and downscaling
- Programmable color matrix processor
- Adjustable color field durations

Perfect for Portables

The Displaytech WVGA panel is a compact, low-power display device designed for a wide range of magnified color display applications, including pico projection, head-mounted displays, and electronic viewfinders. This integrated solution incorporates the display panel and control circuitry in a compact package. This product takes advantage of the fast switching speeds and superior optical qualities of our patented ferroelectric liquid crystal (FLC) materials, delivering full-color video images free of motion smearing. The small size of the display allows for innovative end product designs while the low power consumption extends product battery life. Industry-standard digital interfaces are supported for easy product integration.

Block Diagram

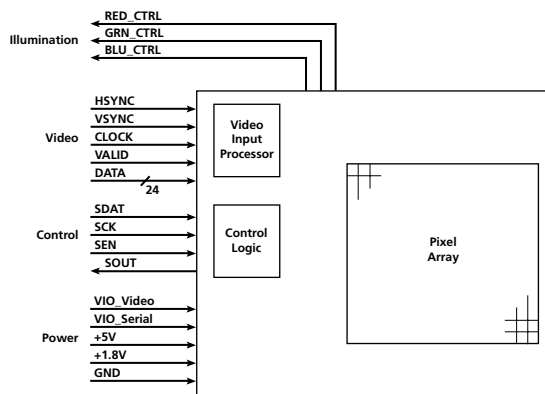

Supported Interfaces

- 24-bit RGB-parallel data, Hsync, Vsync, Valid, Clock
- 24-bit YCrCb 4:4:4 data, Hsync, Vsync, Valid, Clock
- 16-bit YCrCb 4:2:2 data, Hsync, Vsync, Valid, Clock
- Industry-standard 4-wire serial interface (SPI-like)

Applications

- Pico projectors
- Head-mounted displays
- Digital still camera viewfinders
- Video camcorder viewfinders
- Wireless communication devices
- Ultra-portable display applications

Product Specifications

General	Format	852 x 480 full-color pixels
	Active Area Diagonal	11.49mm (0.45-inch)
	Pixel Pitch	11.75 μ m x 11.75 μ m
	Fill Factor	91.7%
	Color Depth	24-bit RGB
	Frame Rate	60Hz NTSC video input rate 50Hz PAL video input rate
	Package	23.4mm x 9.8mm x 3.6mm
Optical*	Reflectivity	62%
	Contrast Ratio	300:1
Electrical	Supported Interfaces	Video Data: 24-bit RGB, 24-bit YCrCb 4:4:4, 16-bit YCrCb 4:2:2 Video Timing: Hsync, Vsync, Valid, Clock Control: Sdat, Sck, Sen, Sout Industry-standard 4-wire serial interface (SPI-like)
	Connector	45-pin, 0.30mm-pitch
	Power Consumption*	Total module: 85mW (Display panel + Integrated controller)
	Power Supply Voltages	Core: 1.8V (\pm 8%) Analog: 5.0V (\pm 10%)
	I/O Input Level	VIO_Video sets level for video signals: 1.8V–3.3V (\pm 8%) VIO_Serial sets level for serial signals: 1.8V–3.3V (\pm 8%)
Thermal	Operating Temperature	-10°C to +70°C
	Storage Temperature	-30°C to +80°C
*Note: Typical values at standard operating conditions and room temperature.		

Contact Us

To find out more about product specifications and availability, visit micron.com/flcos.

micron.com/flcos

©2009 Micron Technology, Inc. All rights reserved. Micron, the Micron logo, and Displaytech are trademarks of Micron Technology, Inc. All other trademarks are the property of their respective owners. Products are warranted only to meet Micron's production data sheet specifications. Products and specifications are subject to change without notice. Rev. 7/09 EN.L

